

CHAMPION

Hoist and Equipment

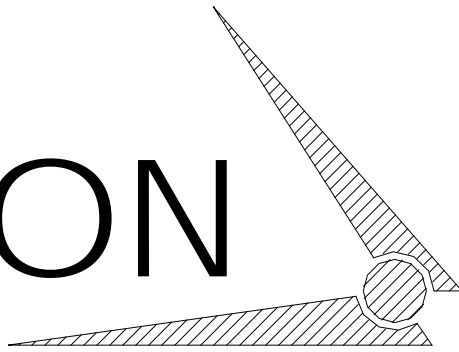

AN AFFILIATE OF

The **Godwin**
 **Group**

200 CHAMPION DRIVE
DUNN, NC. 28334
(910) 897-4995 FAX: (910) 897-7306

FRONT MOUNT TELESCOPIC HOIST

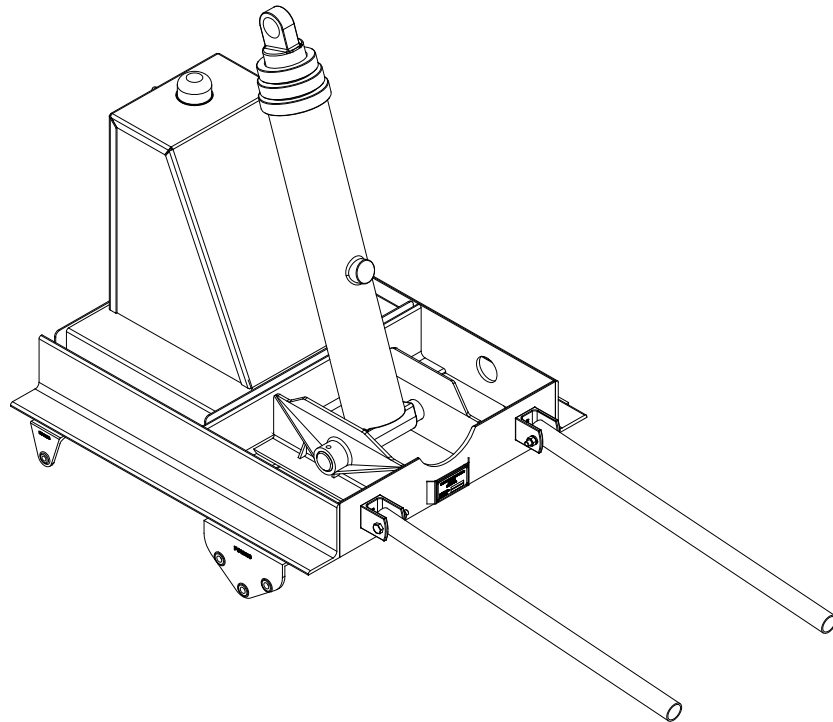

Operation & Installation Manual

CHAMPION HOIST & EQUIPMENT

200 Champion Drive

Dunn, N.C. 28334

800-649-4995

06/06/2011

FRONT MOUNT TELESCOPIC HOIST

Table of Contents

Page 4	Service Information
Page 5-6	Operations and Service Do's & Don'ts (SAFTY INFORMATION)
Page 7	Hoist Operation Instructions
Page 8-10	Champion Subframe Hoist Installation Procedures
Page 11	Instructions to Reverse a C102 Pumps Rotation
Page 12	Hydraulic Plumbing Diagram
Page 13	Hoist Parts Drawing
Page 14	Stop Cable Installation

CHAMPION
Hoist and Equipment

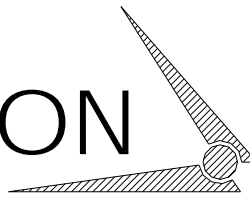

CHAMPION HOIST AND EQUIPMENT

200 CHAMPION DRIVE

P.O. BOX 1147

DUNN, N.C. 28334

Phone# (800) -649-4995

Phone# (910) -897-4995

fax# (910) -897-6822

When calling, specify (parts) - (service) - (sales)

have the following information on hand for

faster service: body model # & serial #

hoist model # & serial #

year, make, type of truck.

this information is provided as indicated

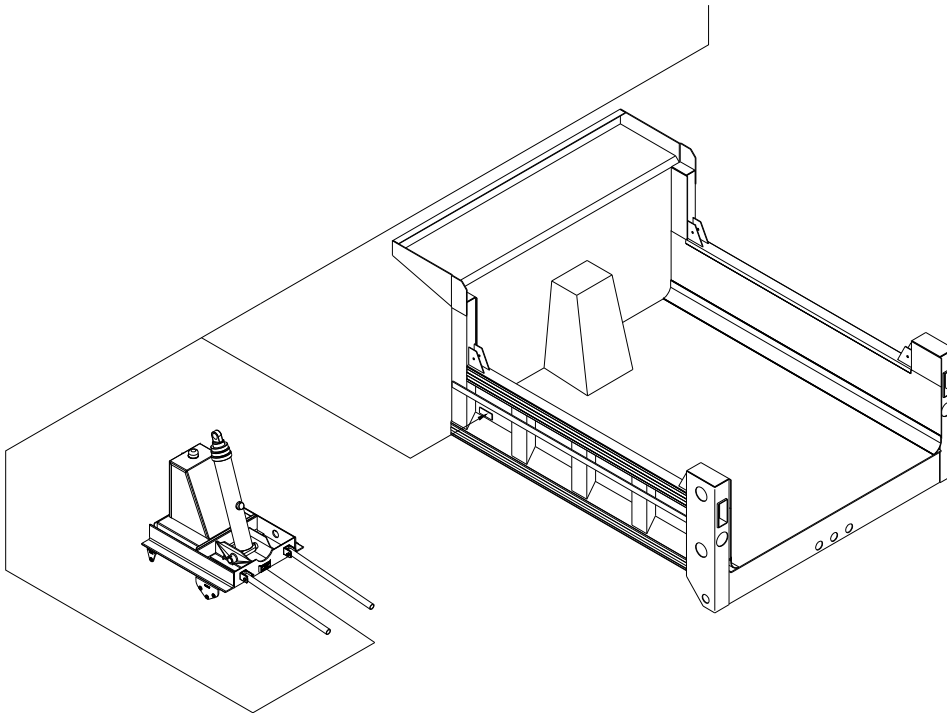

Operations and Service Manual

Do not operate this equipment without fully reading and understanding this manual.

Do not allow unauthorized personnel to operate this equipment.

Do not go underneath a loaded raised bed under ANY circumstances.

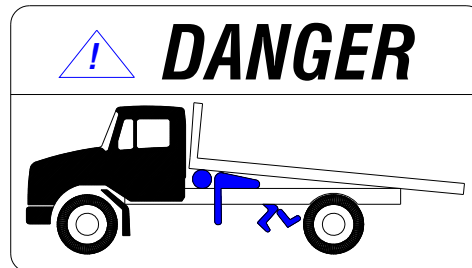

Do not go underneath an unloaded raised bed unless the safety props are properly positioned.

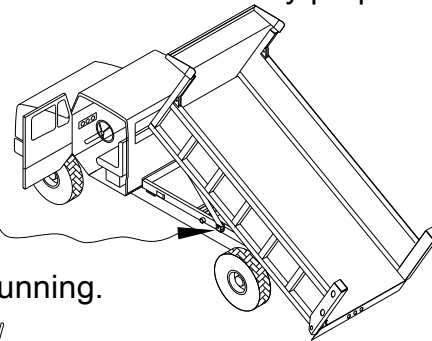

Do not go underneath a truck with engine running.

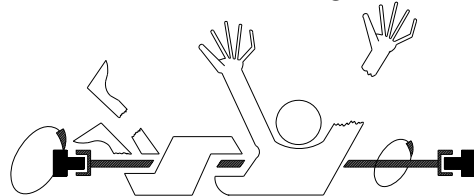

Do not allow controls and area around them to become cluttered with tools, cans, etc.

Do not use hands or other body parts to check for hydraulic leaks.

Do not leave truck unattended with bed raised.

Do not allow personnel to ride in or on the bed.

Do not load the equipment beyond the GVW rating of the vehicle or the hoist rating.

Do not operate the hoist on an unlevel or soft surface.

Do not operate the hoist **UNDER POWER LINES!!**

Do not raise the hoist when vehicle is in motion.

Do not move a vehicle with a raised hoist.

Be sure to.....

- * Follow all Federal, State, Local regulations pertaining to this equipment.
- * Keep unit properly maintained and serviced.
- * Understand and follow all safety decals and keep them in good condition.
- * Check hydraulic oil level weekly.
 - * For PTO driven pumps use HD 32 hydraulic oil.
 - * For electric driven pumps use ATF, automatic transmission fluid.
- * Add correct hydraulic oil to reservoir as needed.
- * Use EP-3 grease for all grease fittings.
- * Lubricate hoist and rear hinge assembly every 90 to 180 days depending on useage.
- * Check all bolts, welds, electrical connections frequently.

When calling for Parts/Service Be Sure To Have....

Flatbed: model number _____
serial number _____
Serial Plate Location _____

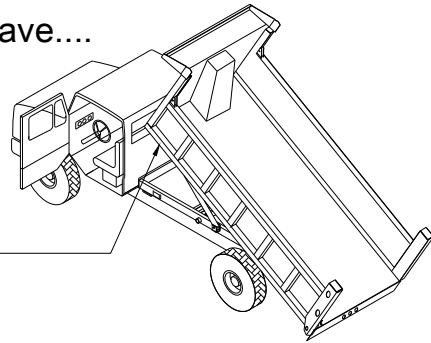

Hoist: model number _____
serial number _____
Serial Plate Location _____

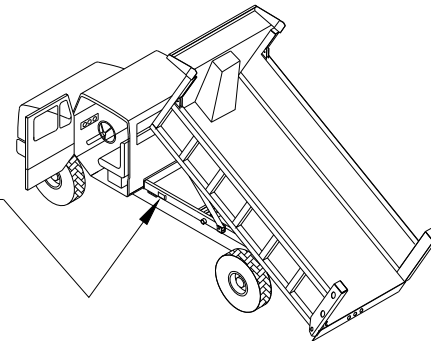

HOIST OPERATION

To Operate Hoist:

- (1) Engage PTO per PTO operation instructions.
- (2) The pump/hoist control should be in the neutral or “hold” position.
- (3) For a manual control - pull to raise, push to lower.
NOTE: Manual push/pull controls require a 1/2 inch mounting hole.
- (4) When bed raises to desired height, push the pump/hoist controls to the center neutral or “hold” position. This will stop bed movement up or down.
- (5) To lower bed - push pump/hoist control.
- (6) Disengage PTO.



FRONT MOUNT TELESCOPIC INSTALLATION INSTRUCTIONS

- STEP #1 LOCATE AND MARK CENTERLINE LOCATION OF REAR HINGE. SEE MP50101.
- STEP #2 AFTER MARKING CENTERLINE OF REAR HINGE, REMOVE EXCESS CHASSIS AS SHOWN IN DETAIL "C" ON MP50101.
- STEP #3 AFTER REMOVING EXCESS CHASSIS, NOTCH THE CHASSIS AND WELD REAR HINGE TO CHASSIS TO DIMENSIONS SHOWN IN DETAIL "C" WITH 1/2" CONTINUOUS WELDS-BOTH CHASSIS RAILS.
- STEP #4 REFER TO MP50101, AND PLACE LOWER BUNK ONTO MOUNTING BRACKETS RESTING ON THE CHASSIS AT THE APPROPRIATE LOCATION.
- STEP #5 AFTER PLACING LOWER BUNK ON CHASSIS, WELD LOWER BUNK MOUNTING BRACKETS TO LOWER BUNK. SEE MP50101 DETAIL "B".
- STEP #6 AFTER BRACKETS ARE SECURELY WELDED TO LOWER BUNK, DRILL 1/2" DIA. (4) HOLES THRU MOUNTING BRACKETS AND CHASSIS AS SHOWN ON MP50101 DETAIL "B", AND INSTALL HARDWARE, ON BOTH CHASSIS RAILS.
- STEP #7 MOUNT HYDRAULIC PUMP TO PTO. BEFORE MOUNTING, CHECK ROTATION OF PUMP. IF PUMP ROTATION HAS TO BE CHANGED, SEE MP50078.
- STEP #8 PLUMB HYDRAULICS PER CORRECT DIAGRAM PD40036.
- STEP #9 AFTER HYDRAULIC CONNECTIONS ARE COMPLETED, INSTALL CABLE ASSEMBLY IN CAB OF TRUCK.
- STEP #10 FILL RESERVOIR FULL OF HYDRAULIC OIL.
- STEP #11 POSITION BODY OVER TRUCK, EXTEND CYLINDER ROD TO BODY LIFT POINT. LOWER BODY TO CHASSIS, ADJUST THE POSITION OF THE BODY ALONG THE CHASSIS SO FRONT OF BODY IS FLUSH WITH THE FRONT OF THE LOWER BUNK SUBFRAME.
- STEP #12 SET SPACER BLOCKS ON TOP OF CHASSIS IN SUCH A WAY THAT THEY WILL NOT INTERFERE WITH THE LOWER BUNK & RESERVOIR TANK.
- NOTE: THE SPACER BLOCKS WILL BE WELDED TO BODY MAIN RUNNERS. DO NOT WELD TO MAIN RUNNERS UNTIL UPPER BUNK CONNECTION IS COMPLETELY INSTALLED!! SEE MP50101, DETAIL "C" ITEM 6.

GODWIN MANUFACTURING FRONT MOUNT TELESCOPIC INSTALLATION INSTRUCTIONS

STEP #13 NOW THAT THE UPPER BUNK IS SECURELY ATTACHED TO THE BODY, WELD THE REAR HINGE FLIPPERS TO THE BODY MAIN RUNNERS AS INDICATED ON MP50101.

STEP #14 WELD SPACER BLOCKS ON BODY MAIN RUNNERS.

STEP #15 INSTALL SAFETY PROPS & PROP CUPS IN SUCH A MANNER THAT THE PROP IS ANGLED SLIGHTLY TO THE REAR.

STEP #16 RAISE BODY WITH HOIST POWER ABOUT THREE FEET, MAKING SURE THAT THE RESERVOIR IS FULL OF OIL, UNTIL THE CYLINDER IS FULLY EXTENDED AND SAFETY PROPS ARE IN PLACE!! OPEN THE BLEEDER VALVE ON THE CYLINDER AND PURGE AIR OUT OF CYLINDER UNTIL A STEADY STREAM OF OIL EXPELS. CLOSE VALVE AND LOWER BODY BACK TO CHASSIS AND REPEAT SEVERAL TIMES.

NOTE: AFTER BLEEDER VALVE IS OPENED, THE BODY WILL DROP SLOWLY UNTIL REACHING HYDRAULIC OIL.

NOTE: NEVER WORK ON A RAISED EMPTY BODY WITHOUT SAFETY PROPS IN PLACE!!

STEP #17 INSPECT ALL WELDS AND CHECK ALL HARDWARE/PLUMBING CONNECTIONS FOR LOOSENESS &/OR LEAKS. REPAIR AS NECESSARY.

STEP #18 INSTALL BODY STOP CABLE ON PUMP USING A 1/8" CABLE CLAMP & TIGHTEN SECURELY. WELD STOP BLOCK SECURELY TO THE LAST BODY CROSS SILL AS SHOWN ON MP50090. ELEVATE BODY TO THE DESIRED HEIGHT, TYPICALLY 4-6 INCHES LESS THAN FULL STROKE OF CYLINDER WITH VALVE IN NEUTRL POSITION. PULL CABLE THRU STOP BLOCK AND TIGHTEN SET SCREW. RAISE BODY & TEST STOP CABLE ASSY. TO ENSURE IT IS WORKING PROPERLY.

THE STOP CABLE IS A SAFETY DEVICE USED TO LIMIT BODY DUMP ANGLE AND TO PREVENT CYLINDER FROM OVER EXTENDING.

STEP #19 GREASE ALL PIVOT POINTS AND GREASE FITTINGS.

DETAIL "A"

WALKING BEAM TANDEM AXLE

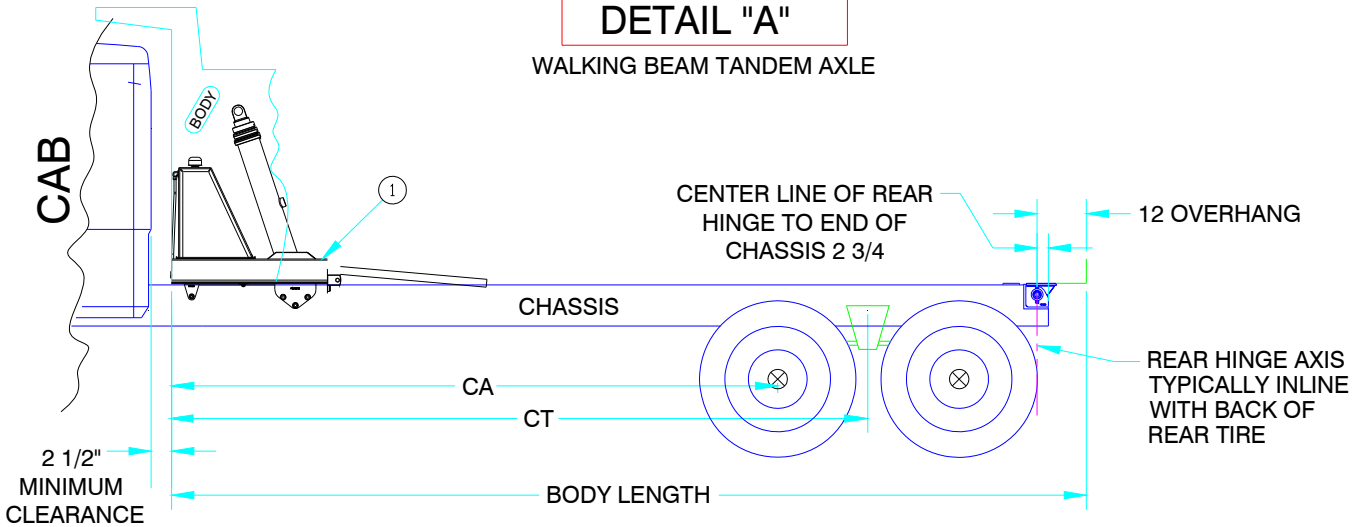

DETAIL "B"

SHACKLE TYPE SUSPENSION

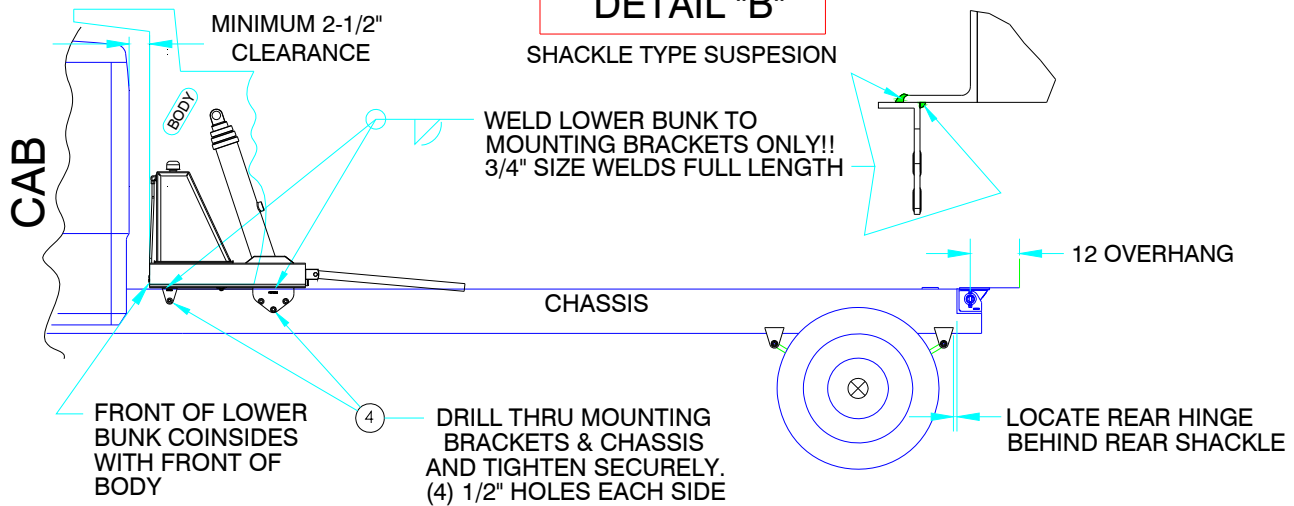

DETAIL "C"

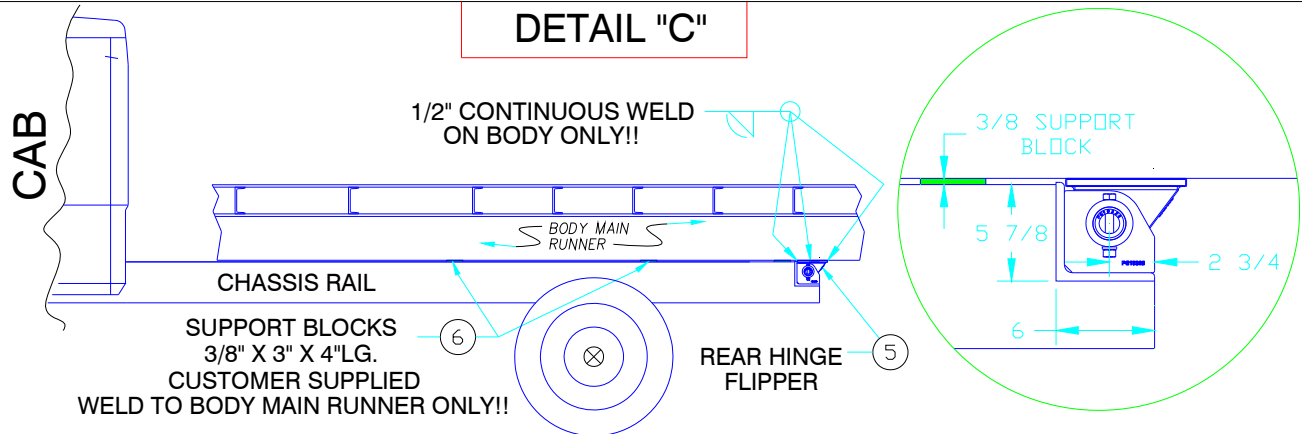

FRONT MOUNT TELESCOPIC HOIST INSTALLATION DIMENSIONS AT A 45° ANGLE

HOIST	CA SINGLE AXLE	CT TANDEM AXLE	BODY LENGTH
63108T	96"	96"	13'
63120T	102"	102"	13'-6"
73120T	108"	108"	14"
63126T	120"	120"	15'-16'
74135T	120"	120"	15'
74156T	132"	132"	16' - 18'

INSTRUCTIONS TO REVERSE C102 PUMP ROTATION

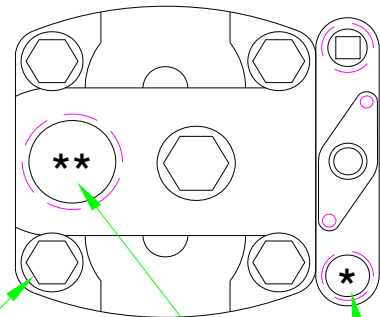
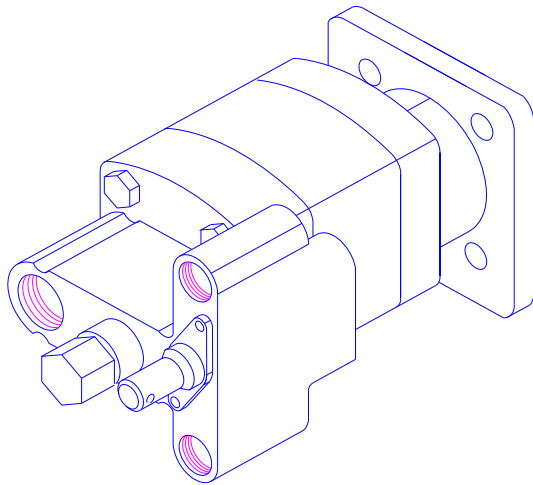

STEP #1 SECURELY MOUNT PUMP FLANGE IN VISE
SHAFT DOWN!

STEP #2 REMOVE (4) HEX BOLTS, WASHERS.

** SUCTION PORT

STEP #3 LIFT OFF VALVE AND CENTER SECTION OF
PUMP LEAVING FRONT COVER AND GEARS
IN PLACE, AND ROTATE 180°.

* CYLINDER PORT

STEP #4 LOWER CENTER SECTION AND VALVE ONTO
FRONT COVER AND GEARS BEING CAREFUL
NOT TO DISTURB POCKET SEALS IN TRUST
PLATES. (IF NEEDED GLUE IN WITH CHASSIS
GREASE) .

STEP #5 REINSTALL BOLTS AND WASHERS AND EVENLY
TORQUE ASSEMBLY BOLTS TO 200 FOOT LBS.

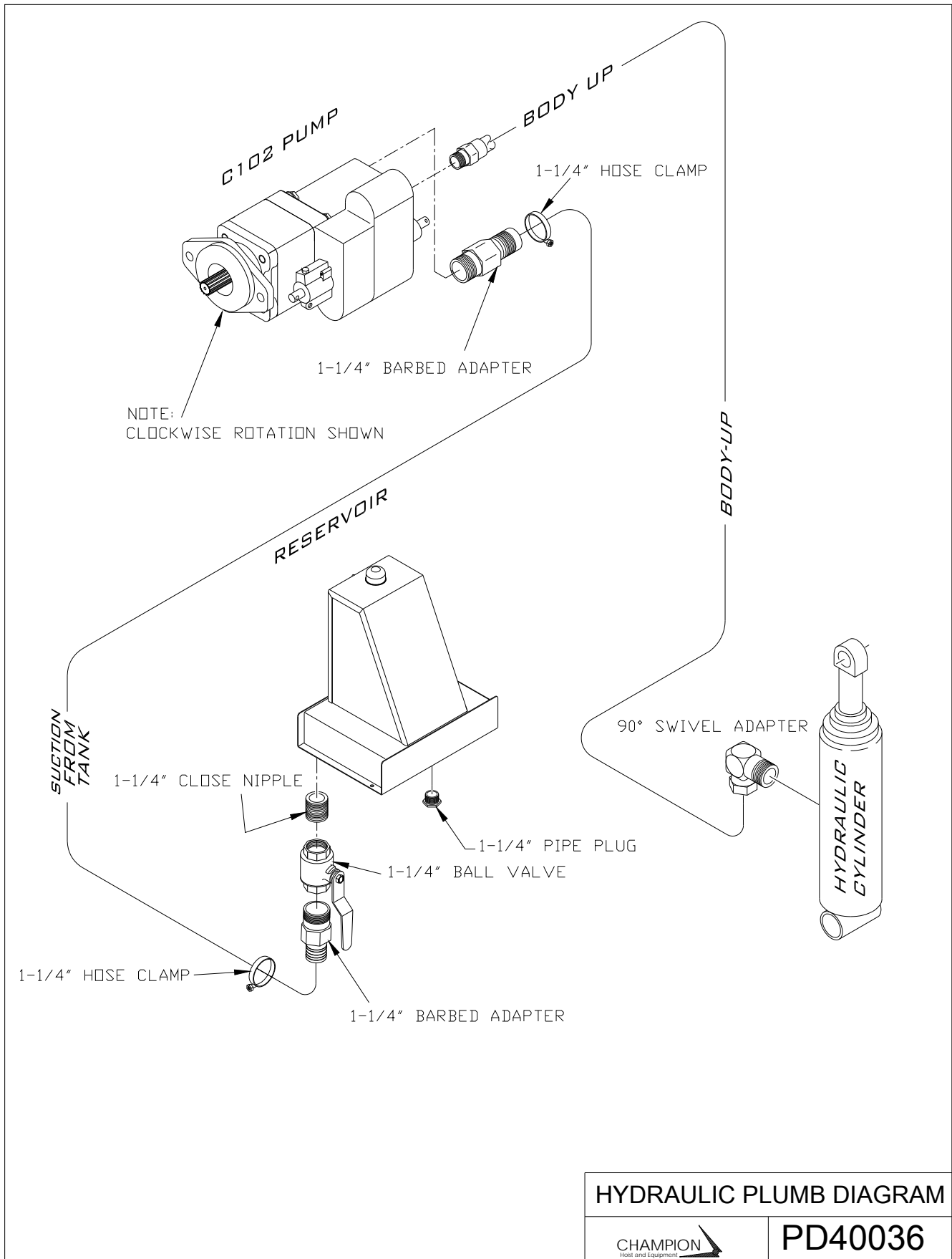

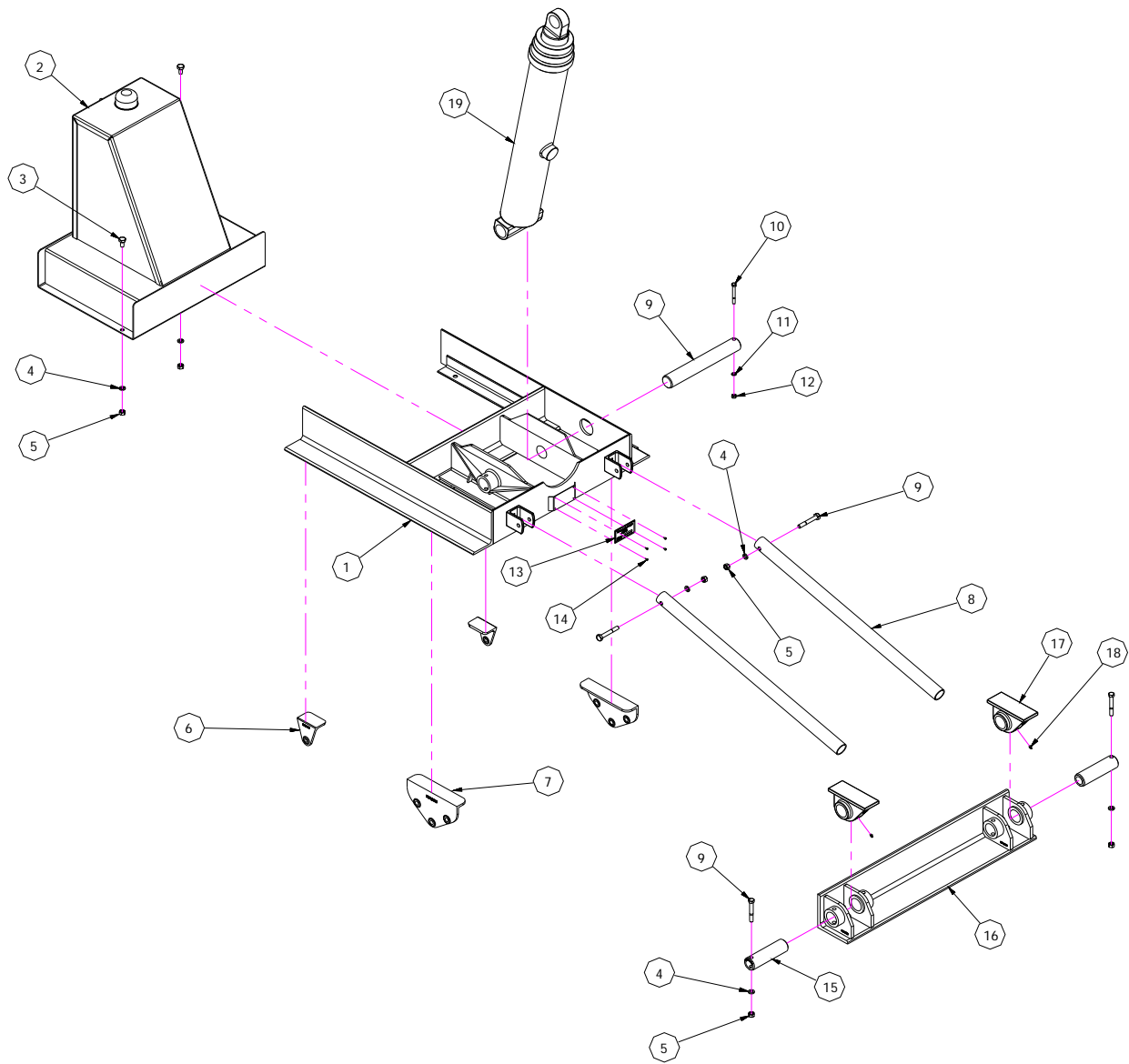

Parts List			
ITEM	QTY	PART NUMBER	DESCRIPTION
1	1	W13106C	WELDMENT, LOWER BUNK
2	1	A15067	RESERVOIR ASSEMBLY
3	2	102-405-A1	HEX BOLT, 1/2-13 UNC X 1
4	6	118-5-A1	LOCK WASHER, 1/2
5	6	116-5-A1	HEX NUT, 1/2
6	2	PC13280C	MOUNTING BRACKET 4"
7	2	PC13278C	MOUNTING BRACKET 10"
8	2	SM13033C	STAND, SAFETY
9	4	SM13105C	CYLINDER PIN
10	2	102-214	HEX BOLT, 3/8 -16 UNC X 3 1/4"
11	2	116-5-A1	LOCK WASHER, 3/8
12	1	116-3-A1	HEX NUT, 3/8
13	1	P10200C	SERIAL PLATE
14	4	PAAP43	POP RIVET, 1/8
15	2	PC10523C	HINGE PIN 2"
16	1	W13359C	REAR HINGE WELDMENT
17	2	PC10335C	REAR HINGE BLOCK
18	2	PT7608	GREASE FITTING
HYDRAULIC CYLINDER SIZES			
19	1	63108T	HYDRAULIC CYLINDER
19	1	63120T	HYDRAULIC CYLINDER
19	1	73120T	HYDRAULIC CYLINDER
19	1	63126T	HYDRAULIC CYLINDER
19	1	74135T	HYDRAULIC CYLINDER
19	1	74156T	HYDRAULIC CYLINDER



FRONT MOUNT
TELESCOPIC

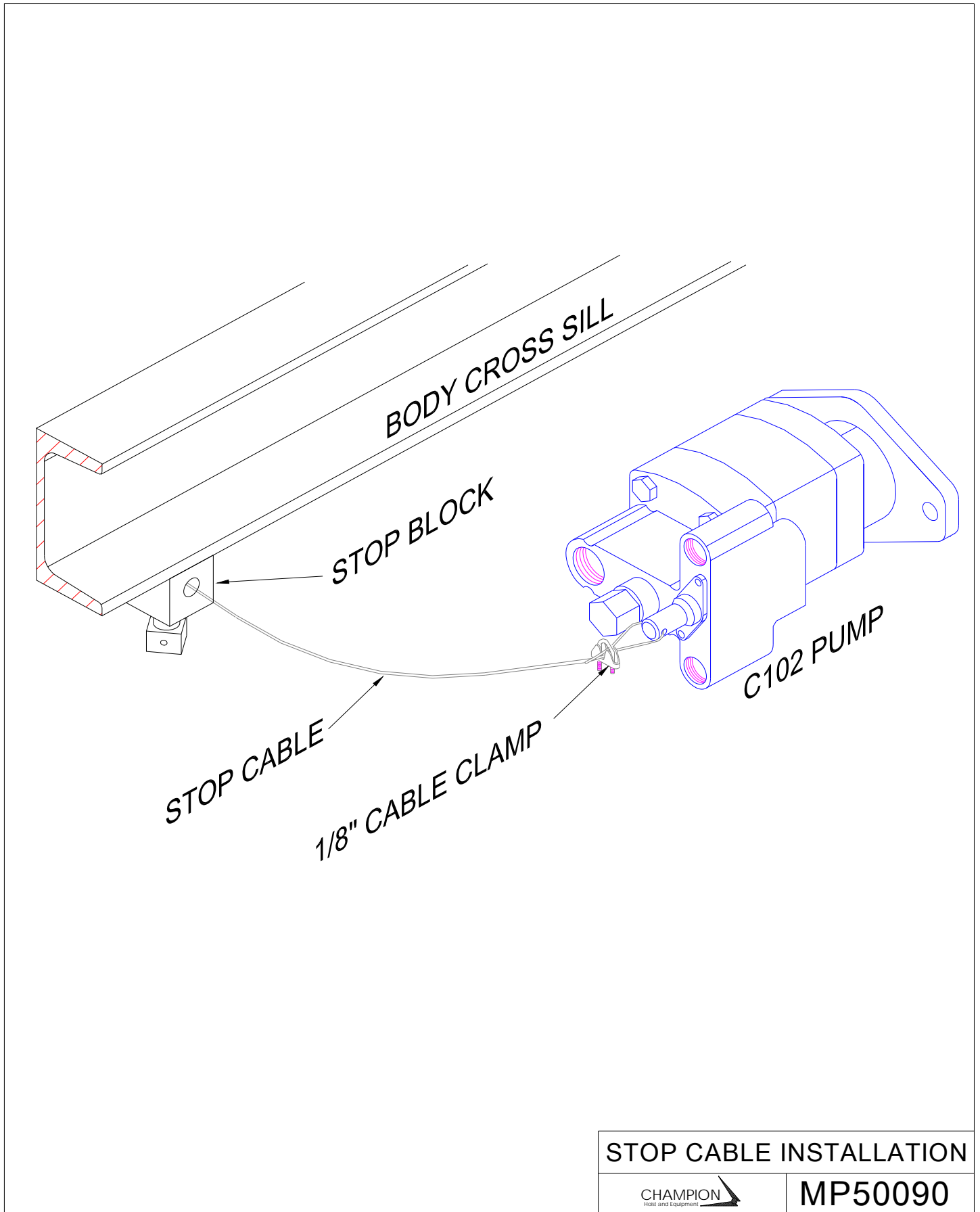

STOP CABLE INSTALLATION

CHAMPION
Hoist and Equipment

MP50090